

FIRE RATING



ITS Warnock Hersey listed



10B Classified up to 180 minutes

SMOKE PERFORMANCE



The rubber seal in this gasket provides protection from smoke infiltration in accordance with provisions of NFPA 101 Life Safety Code and NFPA 80 Standard for Fire Doors and Other Opening Protectives

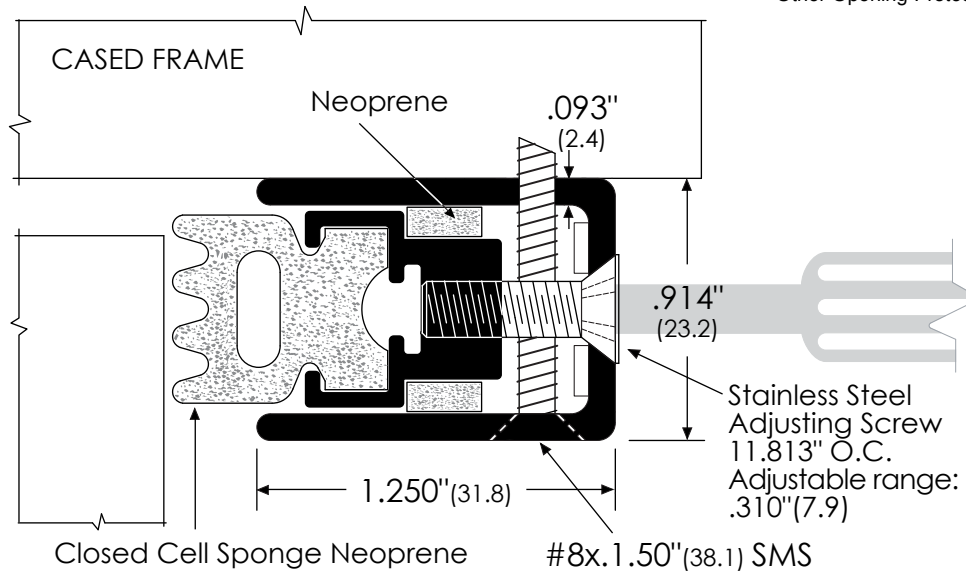

Legend:

AA = Clear Anodized
D = Dark Bronze Anodized
G = Gold Anodized

ANSI/BHMA

Head & Jamb

#170AA / 170D / 170G

R3C264
R3C204



415 Concord Avenue tel: 718.585.3230
Bronx, NY 10455 fax: 718.292.2243
email: zero@zerointernational.com
web site: www.zerointernational.com

Part No:

170

Notes:

Part Description:

Adjustable Sealing System
- Closed Cell Sponge Neoprene

Provided By:

Customer Name:

Job No:

Date: